



## DISPENSING PERISTALTIC PUMP LBX P10+ Touch

*Please read the User Manual carefully before use and follow all operating and safety instructions!*



# user manual

english

# User Manual



## Dispensing Peristaltic Pump P10+ Touch

### Important notice

This instrument is designed for laboratory usage only. Please read this manual carefully before installing or operating this equipment. The instrument shall not be modified in any way. Any modification will void the warranty and may result in potential hazard. We are not responsible for any injury or damage caused by any non-intended purposes and modifying the instrument without authorization.

1. Check the voltage specified on the name-plate and ensure it matches the line voltage in your location.
2. Install the instrument in a clean, dust-less, and ventilated area under 40°C.
3. Never spray flammable or toxic materials.
4. If the following occurs, turn off the pump and disconnect the power plug (pull the plug rather than holding the power line):
  - 4.1 Liquid spilled on the pump
  - 4.2 You think the pump needs maintenance or repair
5. Customer's power outlet must have a reliable earth ground
6. If the supply cord is damaged, please contact the manufacturer or your service agent for replacement to avoid hazard.

### Service

In order to guarantee this equipment Works safely and efficiently, it must have a regular maintenance. In case of any faults, do not try to repair it yourself. If help is needed, you can always contact your dealer or Labbox via [www.labbox.com](http://www.labbox.com)

Please provide the customer care representative with the following information:

- Serial number
- Description of problem
- Your contact information

# PART 1 Matters needing attention

## >>Matters needing attention .....

Please read the operating instruction manual carefully before operating this equipment.

### \* Safety:

The staff responsible for the installation or maintenance of this equipment should have the experience and ability to carry out related work.

This product is not applicable to the ATEX explosion-proof directive and cannot be used in flammable and explosive environments.

When pumping dangerous liquids, please follow safety precautions.

Please determine whether you need to wear personal protective equipment when operating the pump in accordance with the nature of the transfer fluid and industry specifications.

Non-professionals should not install this pump with other equipment to reduce safety risks.

For hazardous fluids, a dedicated operation process must be specified to prevent personal injury.

The power plug can disconnect the power supply and drive in an emergency. Do not place the pump in a workplace where it is difficult to cut off the power supply, which is conducive to emergency stop operations.

### \* Tube:

In the event of a tube failure, ensure that the fluid in the pump tube of the pump head can be discharged to a suitable container or drain.

In the event of a pipe failure, make sure that the fluid in the pump head pump pipe can be discharged to a suitable container or drainpipe.

A ruptured tube may cause fluid to splash. Please take appropriate protective measures.

When disassembling the tube, it is necessary to drain the medium and cut off the power supply to ensure that the pipeline is pressure-free.

Ensure that the chemicals to be handled are compatible with the pump head, tubes and Accessories.

### \* Roller:

Do not touch the rollers and rotating spindle when the pump is running.

Keep the rollers clean and dry to reduce tube wear.

Do not lubricate the pump head rollers by yourself. Improper operation may cause the tube to run out or the pump head shell to corrode.

### \* Drive:

There are no user-serviceable parts in the pump.

The power socket on the back of the driver is equipped with a user-replaceable built-in fuse. Only products of the same category can be used to replace the fuse.

The surface of the driver and the pump head are not resistant to organic solvents and strong corrosive fluids. If the liquid is splashed or accumulated, please remove and clean it in time.

## PART 2 Unboxing

### >>Unboxing .....

#### 2.1 Unpacking inspection

Confirm that the pump is packaged in good condition. Please check the packing list, when unpacking, check the product model and the number of accessories, and check whether the parts are damaged during transportation. If you have any questions, please contact us immediately.

The packing list is sent with the goods, and the actual delivery content is subject to the list.

#### 2.2 Product storage

This product can be stored for a long time, but before putting it into operation, please confirm that the drive, pump head or tubes and other accessories can be used normally. The tubes are commonly used consumables. Pay special attention to the use time and expiration date.

## PART 3 Product description

### >>Product description .....

#### 3.1 Principle of Peristaltic Pump Operation

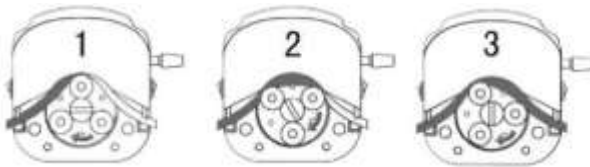

The peristaltic pump uses the rotor to alternately squeeze and release the tube to transfer fluid, just like squeezing a tube full of fluid with a finger. As the finger slides forward, when a negative pressure is formed in the tube, the liquid flows with it.

◆

## 3.2 Product features

- ① Multiple modes: There are two working modes of transmission and distribution, which can be used for repeated timing and quantitative filling.
- ② LCD touch: 3.5-inch color LCD, Chinese and English display, touch screen control
- ③ Return suction function: You can customize the speed angle of reverse operation to prevent liquid dripping.
- ④ Data storage: 9 sets of data can be stored for users.
- ⑤ Support external control: support RS485/MODBUS communication protocol, analog control, foot switch control.

## 3.3 Product structure

### • Drive

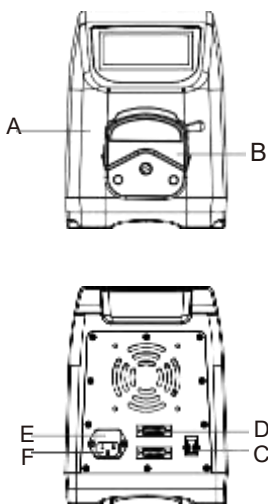

- A: Drive  
B: Pump head  
C: Power switch  
D: External interface  
E: Fuse  
F: Power socket



### 3.4 Technical parameter

	PUMP-3*T-001	PUMP-6*T-001
Max Speed	300rpm (Reversible)	600rpm (Reversible)
Speed resolution	0.1rpm	0.1rpm
Max flow	1140ml/min	2280ml/min
Display mode	LCD (EN and CN)	
Speed control mode	Touch screen + keypad	
Power Supply	AC220V±10% (Standard)	
Return suction angle	10°~720° (0° is no return suction)	
Return suction speed	10-300rpm	10-300rpm
Power	<35W	<50W
External control interface	DB-15	
External control method	Start control/direction control/speed control (0-5V, 0-10V, 4-20mA optional) RS485 serial communication	
Ambient temperature	0°C-40°C	
Protection level	IP31(Indoor use, avoid long-term exposure to ultraviolet rays)	

## PART 4 Product installation

>>Product installation .....

### 4.1 Pump head/pump tube installation

 Before performing any loading, unloading or maintenance activities, be sure to disconnect the pump from the main power supply.

#### CF pump head installation diagram:

YZ1515x (YZ2515x)

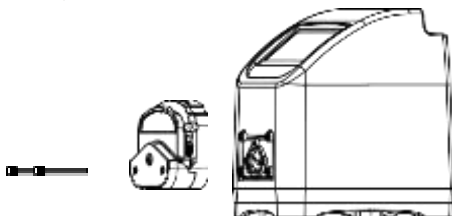

#### CF pump tube installation diagram:

YZ1515x (YZ2515x)



## 4.2 Installation suggestions and precautions

### Installation suggestions

- >> Application accessories such as foot switch, countersunk head, check valve, filling nozzle, connector, etc. can be selected according to actual conditions.
- >> For the size and selection of the tube, please refer to 3.3 Product Structure • Pump head/tube selection and reference flow Related Content.
- >> For pump head models and options, please refer to 3.3 Product Structure • Pump Head/tube Selection and Reference Flow Related Contents.

- ① Before cleaning, maintaining and installing the equipment, be sure to disconnect the control power supply;
- ② The driver should be placed on a flat and rigid surface;
- ③ The ambient temperature of the pump should not exceed 104° F (40° C), and air circulation should be ensured to ensure the heat dissipation of the pump;
- ④ The start-stop key (shortcut key) on the operation panel can quickly change the direction and control the start-stop, but it is recommended to install an emergency stop device on the main circuit of the power supply to ensure higher safety;
- ⑤ Make sure that the inner wall of the tube is clean and free of foreign matter before use. The shorter the pipeline, the better, and the suction and lift should not be too long;
- ⑥ Determine the running direction of the pump (forward and reverse) according to the specific location of the fluid placement and supporting machinery on site, which is conducive to later operation;
- ⑦ In order to meet the requirements of flow and flow rate, a peristaltic pump tube with matching diameter is required;
- ⑧ The pump itself has self-priming characteristics, which can effectively prevent the backflow of liquid. Generally, there is no need to install valves at the outlet and inlet of the tube. You can also install a one-way valve in the pipeline according to actual needs to avoid fluid leakage when the pump head and tube fail.

### Precautions

- The diameter of the pipeline at the inlet is not less than the inner diameter of the pump tube, and a delivery pipe with a diameter  $\geq$  the inner diameter of the pump tube should be selected.
- When transferring viscous liquids, it is necessary to maintain a low speed operation to improve the filling efficiency. It is recommended to connect a flexible tube no less than 1 meter between the inlet and the outlet to reduce the pulse and reduce the pulse loss.
- Try to put the pump at the same level or a lower level of the liquid to be transferred to

improve the transfer efficiency of the pump.



- To replace a new tube or liquid, re-calibrate the liquid volume to ensure the accuracy of liquid transmission.
- When the peristaltic pump is running, all valves in the pipeline must be opened normally.
- Control wires and power wires are not allowed to have sharp bends, and it is not recommended to bundle them together.
- This product cannot be used for the transmission of any chemical substances incompatible with the pump head and tube.

## PART 5 Product operation

### >>Product operation .....

#### 5.1 Line connection

Power connection:

-  AC220V  $\pm$  10% (standard) power supply.
-  Ensure that all power supplies are matched to equipment power and are well grounded.
-  The position of the pump should ensure that it is convenient to disconnect the power supply when operating the equipment.

#### Power supply wiring diagram:

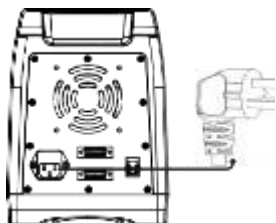

#### External control wiring diagram:

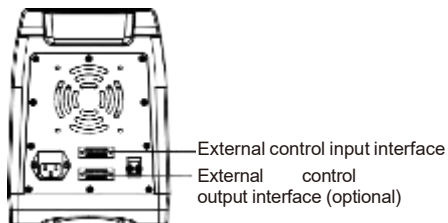

**Note:** For the specific external control input/output interface definition, please refer to "5.5 External Control Operation" for details

## 5.2 Power-on

### • Power-on inspection

- ① Check whether the pump pipe has been installed correctly, and whether the tube inlet pipe and outlet pipe have been correctly connected.
- ② Check whether it is connected to a matching power supply.
- ③ Check whether the peristaltic pump has been installed according to "4.2 Installation suggestions and precautions".

After the pump is turned on, the LCD display is powered on to enter the main interface, and you can start specific settings and operations.

### • The default factory settings for the first boot

Factory setting: P10+ Touch series peristaltic pump, the pump head model/tube model has been set before leaving the factory, subject to the actual product purchased. If multiple types of tubes are needed, the model set is the tube with the largest diameter.

After the pump is turned on, it starts to run with the default set value, and all operating parameters can be changed by touch screen operation (see 5.4 Menu Function Operation)

**Note:** It supports communication in advance, and the factory settings can be adjusted according to user needs.

## 5.3 Operation panel and display

### • Operation panel

① Shortcut key area  
(key operation)

⑤ Image indication

Running animation (display)

Directionfull speed indication (display)



② Graphic menu area (touch screen operation)

③ Filling parameter input area (touch screen operation)

• Filling Volume • Pause time  
• Filling Time • Filling Number

④ Status parameter display area (display)

• Pump Head Model • Speed • Filling Volume  
• Pump Tubing Model • Flow • Filling Number

### (1) Shortcut key area



Full Speed—Quickly empty and clean the tube, turn it at full speed after opening, and then press to restore the original state.



HOME—In other operation interfaces, press and quickly return to the main interface.



Direction—Change the direction of drive rotation, ↺ means counterclockwise rotation and ↻ means clockwise rotation.



Start & Stop—Each time it is pressed, the start/stop state is changed.

## (2) Graphic menu area



- ① **Set:** Function operation main menu, peristaltic pump can be set accordingly.
- ② **Data :** Save new data quickly and apply saved data.
- ③ **Lock:** Lock screen, unable to touch screen operation Unlock, touch screen operation.
- ④ **Voice:** Voice mode, Silent mode.
- ⑤ **Remote:** Pump operation, Remote operation.

## (3) Filling parameter input area

### ① Mode 1: Filling mode(default mode)

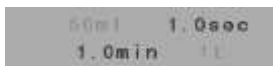

- Filling Volume (ml/L)
- Pause time (sec/min)
- Filling Time (sec/min)
- Filling Number (t)

Filling Time: Real-time countdown display      Pause time: Real-time countdown display

### ② Mode 2: Transmission mode



Flow (ml/min)      Flow+      Flow-

(Flow+- Real-time adjustable)

## (4) Status parameter display area

### ① Filling mode



- Pump Head Model
- Speed (rpm)
- Filling Volume (ml)
- Pump Tubing Model
- Flow (ml/min)
- Filling Number (t)

**Speed:** The system automatically displays according to the flow

**Filling Volume:** Real-time display of filling liquid volume, Do not accumulate by Filling Number.

**Flow:** The system automatically displays according to the filling volume and filling time.

**Filling Number:** Real-time update number display, Accumulate according to Filling Number.

**Note:** After each start, until it stops automatically, it is a complete filling cycle; manual stop will end immediately.



## ② Transmission mode







• Pump Head Model • Speed (rpm) • Timing (sec)  
 ∴ Pump Tubing Model ∴ Flow (ml/min) ∴ Flow volume

**Note:** Each start and stop is a complete timing and Flow volume display. After stopping and then turning on, the display will start again.

## (5) Image indication

① Running animation , Display the running status of the pump: display  rotation when running; display  no rotation when stopped.

② Direction/full speed indication,  Clockwise,  Counterclockwise,  Full speed-clockwise,  
 Full speed-Clockwise-counterclockwise.

## 5.4 Menu function operation

### • Filling parameter setting instructions

Filling volume——Required liquid volume per bottle

Filling time——Time required to complete Filling Volume

Pause time——Filling pause time

Filling number——Total number of bottles to be filled

Filling volume:			
Max:9999L	Min:0.001ml		
124.5 ml			
1	2	3	C
4	5	6	U
7	8	9	Esc
0	.	OK	

① Main interface→Click the filling quantity value, will show the small keyboard.→Input value (As shown)

② Max: Min: -show the max and min. value for the using pump head and tubing, can only input the value in this range (Filling volume : 0.001ml-9999L, This value is the limit of the pump)

③ U- unit setup: ml/L

④ C-Delete Esc-Exit OK-Confirm **Note:** The pump does not support settings when running

Filling volume setting

-----

Filling time:			
Max:9999min	Min:0.1s		
234.5 s			
1	2	3	C
4	5	6	U
7	8	9	Esc
0	.	OK	

### Filling time setting

- ①Main interface→Click the Filling time quantity value, will show the small keyboard→input filling time (As shown)
- ②Max: Min: -Display the upper and lower set limits of the time corresponding to the current filling volume, this is the input range of the filling time (Filling time: 0.1s-9999min, This value is the limit of the pump)
- ③U-unit setup: s (sec) / m (min)
- ④C-Delete Esc-Exit OK-Confirm **Note:** The pump does not support setting during the filling cycle

Pause time:			
Max:9999min	Min:0.1s		
124.5 s			
1	2	3	C
4	5	6	U
7	8	9	Esc
0	.	OK	

### Pause time setting

- ①Main interface→Click the Pause time quantity value, will show the small keyboard→Input value (As shown)
- ②Input range: 0.1s-9999min
- ③U-unit setup: s (sec) / m (min)
- ④C-Delete Esc-Exit OK-Confirm **Note:** The pump does not support setting during the filling cycle

Copy number:			
Max:9999t	Min:0t		
12411			
1	2	3	C
4	5	6	
7	8	9	Esc
0	.	OK	

### Copy number setting

- ①Main interface→Click the Filling number quantity value,→ Input value (As shown)
- ②Input range: 0-9999 times,0 on behalf of the infinite time
- ④C-Delete Esc-Exit OK-Confirm **Note:** The pump does not support settings when running

### **Note:**

When filling, Filling time and Pause time, with countdown display function on the main interface;

When filling, Status parameter display area-Filling volume and Filling number are updated and displayed in real time.

### • System setting instructions

\*Main interface→Click  →Click **System**→Enter the system setting options interface (as follows):

Head	Tube	EXInput	ExOutput	Uart	Suck Back	Language	Exit
------	------	---------	----------	------	-----------	----------	------

System:

Head	Tube
ExInput	ExOutput
uart	SuckBack
Language	Exit

System setting interface

**Head** Select the current use of the pump head models.

Main interface → Click  → **system** → Click **Head** → Select pump head model → Click **Enter**, save and exit; Click **Cancel**, exit without saving.

**Tube** Select the current use of the pump tubing models.

Main interface → Click  → **system** → Click **Tube** → Select pump tube model → Click **Enter**, save and exit; Click **Cancel**, exit without saving.

**Note:** If you only replace the tube, you do not need to select the pump head model again.

Choose a different type of pump head, and the matching tube model will automatically change to provide options.

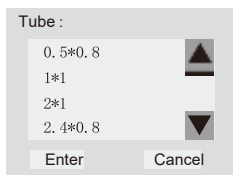
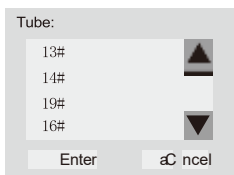

Example: Choose YZ1515x pump head, the optional tube model is as shown above

Example: Choose DG (6) pump head, and the optional tube model is as above

**EXInput-External control input** Select External control input parameters

Main interface → Click  → **system** → Click **EXInput** → External control input option interface :

- ① **Ctrl** → Usrt/Aanlog → Click **Enter**, save and exit; Click **Cancel**, exit without saving.
- ② **Item** → Start Stop/Direction/Speed → Click **Enter**, save and exit; Click **Cancel**, exit without saving.
- ③ **Signal** → Level/Pulse → Click **Enter**, save and exit; Click **Cancel**, exit without saving.
- ④ **Speed** → 0-5V/0-10V/4-20mA/0-10kHz → Click **Enter**, save and exit; Click **Cancel**, exit without saving.

### ExOuput-External control output

### Select External control output parameters

Main interface → Click  → **system** → Click **ExOuput** → External control output option interface:

- ① **Item** → Start Stop/Direction/Speed → Click **Enter**, save and exit; Click **Cancel**, exit without saving.
- ② **Signal** → Level/Pulse → Click **Enter**, save and exit; Click **Cancel**, exit without saving.
- ③ **Speed** → 0-5V/0-10V/4-20mA/0-10kHz → Click **Enter**, save and exit; Click **Cancel**, exit without saving.

### Uart-Communication Settings

### Select the pump communication parameters

Main interface → Click  → **system** → Click **Uart** → Enter the address of the pump on the keypad (default 1) / Baud rate (1200 /2400 /4800/ 9600) → Click **Enter**, save and exit; Click **Cancel**, exit without saving.

- P10+ Touch pump also has 485 serial communication bus interfaces to be connected to the host computer (computer, PLC, SCM).
- PC can simultaneously connect up to 30 devices with 485 serial communication bus interface functions; when using with multiple devices to communicate with the host computer, it must know the machine number for each device, this device ID is the only number that should be connected together, and each machine number of the devices is not the same.
- The factory default value for each pump is “1”; it could be reset by remote controlling through the host computer or by manually changing from the setting menu.
- Change the following steps: Set up — System — Uart — Adress(Default 1) — small keyboard input.

### Suck Back

### Select Suck-back parameters

Main interface → Click  → **system** → Click **Suck Back** → Small keyboard input suck back angle

(10-720deg) / Small keyboard input suck back speed

→ Click **Enter**, save and exit; Click **Cancel**, exit without saving.

PUMP-3\*T-001 (10-300rpm)

PUMP-6\*T-001(10-300rpm)

**Note:** Fillingmode. Pause time should be greater than the suck back time.

## Language Choose Chinese/English

Main interface→Click  →system→Click **Language**→Chinese/EnglishClick **Enter**, save and exit;Click **Cancel**, exit without saving. (**Note:** language customization is available)

\*After completing the required system settings, return to the previous menu or exit to the main interface to perform other operations.

### • Calibration Guide

The P10+ Touch peristaltic pump has a flow calibration function, which can realize high-precision filling. When a new tube is replaced, external conditions change, or other conditions cause a deviation in the flow value, the flow needs to be calibrated to meet the user's requirements for flow accuracy.

(1) Main interface→Click  →Click **Calibration**→Keyboard input calibration value→Click **Next** to enter the calibration interface (or Click **Exit** to return to the previous menu).

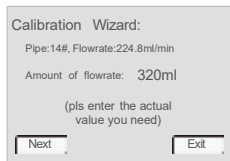

- Tube: Automatically display the tube model currently in use  
- Flowrate: Automatically display the flow rate generated when filling volume and filling time (ml/min)  
- Filling volume: The initial default value is the filling volume displayed on the main interface (Can be input and adjusted according to actual needs)

**Note:** If the amount of liquid to be calibrated is very large and the required time is long, the set value can be reduced according to the filling situation.

(2) Calibration interface:

① Press  to start transmission and display the remaining time. When the remaining time is 0, it will automatically stop and return to the calibration interface

(If you need to stop, click **Cancel**, return to the calibration interface, the value of this transfer fluid is invalid)

② Repeat the calibration 3 times → Enter the actual measured value in turn on the keypad→Click **Next**→Click **Ok**, Save the results to complete the calibration

(Or click **Back**, return to the calibration interface, this time the result is invalid)

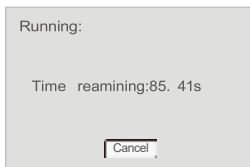

Countdown interface

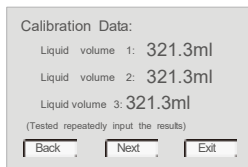

Actual filling volume interface

### • Mode selection instructions

The peristaltic pump has two working modes: Filling mode、Transmission mode

\*Main interface→Click  →Click **Mode**→Select **Filling/Transmission** (Or click **Exit** to return to the previous menu)





Filling mode main interface



Transmission mode main interface

### • Data operation instructions

The peristaltic pump can realize user data storage function: save 9 groups of filling data.

Click the data shortcut  on the main interface to enter the data operation interface.Or -Main interface→Click  →Click **Data**, enter the data operation interface.

No.	Head	Tube	Vol	Copy	Time	Interval
1	YZ1515x	25#	500ml	20	142.9s	3.0s
2						
3						
4						
5						
6						
7						
8						
9						

1 is a set of saved filling data:

- Head: The currently set pump head model
- Tube: The currently set tube model model
- Vol: Filling Volume display
- Copy: Filling Number display
- Time: Filling Time display
- Interval: Pause time display

- ①Del: Select a group of data → Click **del** → **Yes** → complete data deletion
- ②Save: Select a location → Click **save** → **Yes** → Complete the storage of the currently used filling data. (This group of filling data is stored in the selected location. If there is data in this location, the original data will be overwritten).
- ③Use: Select a set of data → Click **Use** → enter the main interface automatically
- ④Exit: Click **Exit**→Automatically return to the main interface

## 5.5 External control operation



Please provide the correct signal to the pin, do not exceed the specified range of the signal value, and do not connect the power supply voltage to other pins to avoid permanent damage.



Make sure that the end of the multi-strand cable is fastened with a cable tie to prevent the risk of electric shock.

### • DB15 The external control interface sketch

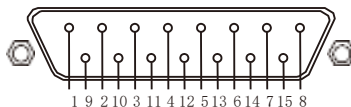

The external control interface sketch

## Drive external control interface (DB-15 description)

### 1、 The using method of the external interface:

- (A) Enabled wire and Ground wire connect or shut, control the entry of the external control.
- (B) Start/Stop wire and Ground wire connect or shut, control the start and stop of the pump.
- (C) Direction wire and Ground wire connect or shut, control the running direction of the pump.
- (D) Between Speed wire and Ground wire, join up 0-5V, 0-10V, 4-20mA, 0-10kHz, etc. controlling wire signal.

### 2、 External control output port provides optional.

### 3、 Description of Outer Space Interface (DB-15)

\*The 15-pin interface on the back of the machine is the controlling interface to operate the machine through the external signals.

Firstly prepare a DB15 connector (with holes) and various colors signal wires, then open the 15-pin interface, weld on the signal wires according to the below sheet, and fix the wires together using the clip on the interface, you may inject some glue to reinforce these wires; and at last install the shell and screws.

#### • External control input

-External control input interface definition

PIN	1	2	3	4	5	6	7	8
DEFINITION	E-c Ground	485 interface A	E-c Ground		Direction	E-c Ground	0-10kHz Input	0-5V Input

9	10	11	12	13	14	15
485 interface B	E-c Ground	Start /stop 1	E-c Enable	E-c Ground	4-20mA Input	0-10V Input

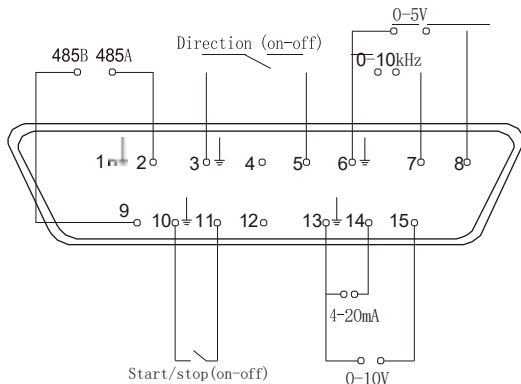

1, 3, 6, 10, 13 are all E-c Ground

External control input (CF) wiring diagram

【External control input line color function definition】

Serial number	Function	Corresponding function of wire
1	485 communication	brown---485A    blue---485B
2	start/stop	brown---start/stop    blue---E-c Ground
3	start/stop、direction	brown---E-c Enable    gray---start/stop    blue-- -direction    black---E-c Ground
4	start/stop、analog input: (0-10kHz/0-5V/0-10V/4-20mA)	brown---E-c Enable    gray---start/stop blue---- 0-10kHz/0-5V/0-10V/4-20mA black    E-c Ground
5	start/stop、direction、analog input: (0-10kHz/0-5V/0-10V/4-20mA)	brown---E-c Enable    gray---start/stop    blue-- -- direction    two-color    0-10kHz/0-5V/0-10V/4-20mA black    E-c Ground
6	start/stop、direction、analog input (0-10kHz/0-5V/0-10V/4-20mA)、485 communication	brown---E-c Enable    gray---start/stop    blue-- -- direction    yellow    0-10kHz/0-5V/0-10V/4-20mA green---485A    red    485B black    E-c Ground
7	start/stop、485 communication	brown---E-c Enable    two-color---start/stop    blue-- -- 485A    gray---485B black---E-c    Ground
8	start/stop、direction、485 communication	yellow---E-c Enable    green---start/stop red--- direction    blue---485A gray---485B    black---E-c Ground

• **External control output**

-External control output interface definition:

PIN	1	2	3	4	5	6	7	8
DEFINITION	//	Enable output B	Start-stop output B	Direction output B	E-c Ground	4-20mA output negative	E-c Ground	E-c Ground

	9	10	11	12	13	14	15
	Enable output A	Start-stop output A	Direction output A	0-10kHz output	4-20mA output positive	0-10V output	0-5V output

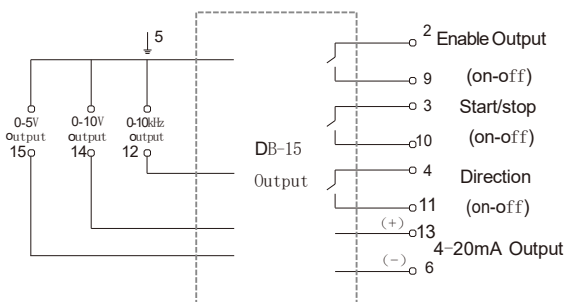

5、7、8 are all E-c Ground

External control output (CF) wiring diagram

**【External control output line color function definition】**

Serial number	Function	Corresponding function of wire
1	Start-stop output	brown---Start-stop output A blue---Start-stop output B
2	4-20mA output	brown 4-20mA output positive blue 4-20mA output negative
3	0-5V/0-10V/0-10kHz output	brown 0-5V/0-10V/0-10kHz output blue E-c Ground
4	Start-stop,4-20mA output	brown---Start-stop output A blue---Start-stop output B gray 4-20mA output positive Black 4-20mA output negative
5	Start-stop,0-5V/0-10V/ 0-10kHz output	brown---Start-stop output A blue---Start-stop output B Gray 0-5V/0-10V/0-10kHz output Black E-c Ground
6	Direction output	brown---Direction output A blue---Direction output B
7	Enable output	brown---Direction output A blue---Direction output B

**Note:** When the external control input/output is analog control speed, there will be some deviation due to different signal source types. If it affects normal use, please contact with Labbox!

**• Foot switch operating instructions**

Foot switch and Hand held dispensing controller are options. These devices only control the start and stop status of the pump, and the running speed and direction are set through the operation panel.

The foot switch is connected to the DB-15 external control interface of the peristaltic pump. Under external control, the start-stop key and the full-speed key are invalid. The HOME key, arrow keys, and touch screen settings are used normally.

**Operation setting:**

- (1) Main interface → Click  → Click **System** → Click **ExInput** → ① Ctr I → Analog → Ok  
 → ② Item → Start Stop → Ok  
 → ③ Signal → Level/Pulse → Ok  
 → ④ After setting, exit to the main interface

The main interface  is displayed as , the setting is successful, and the external control mode is en



- \* Filling mode: It is recommended to use the **Pulse** signal. Press once to complete the entire filling cycle (Set filling numbers) and automatically stop after completion. Press again to restart and stop.
- \* Transmission mode: **Level** signal, Continue to press to continue to run, release it to stop. **Pulse** signal, Press to start, press again to stop.

## PART 6 Troubleshooting and maintenance

### >>Troubleshooting and maintenance .....

**Note:** There are no parts in the pump that can be repaired by the user. If you need repairs, please contact with Labbox!

#### 6.1 Troubleshooting

<p>*No response at boot</p>	<p>&gt;&gt;If a circuit protection device is installed, confirm that the circuit has not tripped                  &gt;&gt;Confirm that the power plug is inserted into a working socket                  &gt;&gt;Check whether the power cord is firmly inserted                  &gt;&gt;Check whether the fuse at the power interface is blown</p>
<p>*The fan and display screen are normal, but cannot be started</p>	<p>&gt;&gt; Check if the device is in external control mode                  &gt;&gt;Check if the keys are working</p>
<p>*The pump is turned on and the pump head cannot run</p>	<p>&gt;&gt;Check if the coupling is damaged                  &gt;&gt;After cutting off the power, manually check whether the pump head is rotating normally</p>
<p>* Low or no flow when the pump is running</p>	<p>&gt;&gt;Check whether the material supply is normal                  &gt;&gt;Check if the pipe is entangled or blocked                  &gt;&gt;Check that all valves are open                  &gt;&gt;Check if the tube is in the middle of the roller                  &gt;&gt;Check whether the tube is cracked or damaged                  &gt;&gt;Check the running direction                  &gt;&gt;Check whether the pump head roller can rotate flexibly</p>
<p>*Pump cannot be controlled in external control mode</p>	<p>&gt;&gt; Check the upper right corner of the LCD, the external control icon  is displayed as                   &gt;&gt; Check whether the external control settings are correctly connected                  &gt;&gt; Check if the signal source is normal</p>

## 6.2 Product maintenance

**Warning:** Before attempting any maintenance, be sure to cut off the power to the pump.

### • Replace the fuse

- ① Place the power switch in the "off" position ( "I" On, "O" Off)
- ② Disconnect the AC power input cord from the outlet.
- ③ Take out the spare built-in fuse from the power socket of the pump.
- ④ Replace the original fuse.

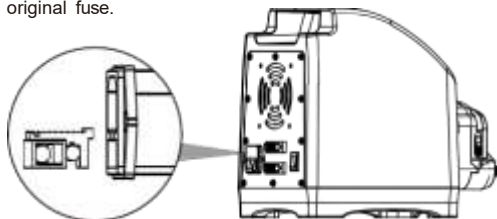

### • Replace the pump head coupling

- ① Place the power switch in the "off" position ( "I" On, "O" Off)
- ② Disconnect the AC power input cord from the outlet.
- ③ Remove the tube pump head and take out the coupling.
- ④ Install a new coupling, install the pump head and pump tube.

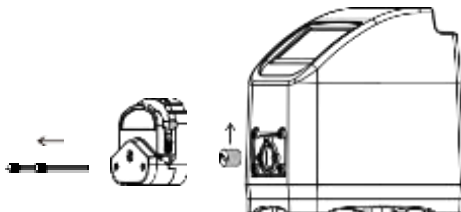

### • Basic maintenance and cleaning

#### Basic maintenance

- ① Open the pump head when it is not working to avoid tube deformation caused by prolonged extrusion.
- ② Keep the pump head rollers clean and dry to prevent surface damage and reduce tube wear; if there is splashing liquid, please wipe it dry as soon as possible.
- ③ Check the wear of the tube regularly and replace it in time to prevent leakage.

- ④ The pump head roller does not need to add lubricating oil, and improper operation may cause the tube to shift or corrode.
- ⑤ Not used to deal with chemical substances incompatible with the pump head or tube.
- ⑥ The pump head is not resistant to organic solvents and strong corrosive liquids. Please deal with it in time if there is effusion.
- ⑦ Please be aware of the storage recommendations and the expiration date of the tube so that it can be used normally after long-term storage.
- ⑧ Built-in fuse, pump head shaft and other replaceable accessories, need to be installed under the guidance of professionals.
- ⑨ It is recommended that the working environment temperature be between 0-40°C.

#### **cleaning**

**Warning:** Before attempting any maintenance, be sure to cut off the power to the pump. When there are stubborn stains on the pump housing, please use a mild detergent to scrub the surface. Do not immerse the pump in liquid or use too much liquid to clean it.

**•Relevant details**

① Labbox will not be responsible for any direct or indirect losses caused by external reasons such as operating errors or human negligence that are not the product's own quality problems.

Direct loss: products, supporting machinery, working environment, surrounding buildings, etc.

Indirect loss: labor loss, profit loss, etc.

② Labbox will not be responsible for the transportation damage caused by the returned products and accessories during the return journey.

③ In any case, the compensation cost received by the customer shall not exceed the actual payment price.

**•Non-warranty scope**

The following conditions are not included in the free maintenance of the warranty:

① The product has exceeded the warranty period.

② Product failure caused by abuse, misuse or accidental damage by Labbox's judgment.

③ Product problems caused by ultraviolet rays or direct light.

④ It is not the damage caused by after-sales personnel in the repair or disassembly process.

⑤ Damage caused by chemical erosion or long-term improper maintenance.

⑥ Product failure caused by force majeure factors such as natural disasters.

⑦ The operator fails to follow the corresponding operation suggestions and requirements, improper loading and unloading, improper maintenance, and improper operation.

⑧ Failures or damages that are not caused by the quality of the product itself.

③ When applying for after-sales service, please provide a clear reason for the return, specific information about the contacted substances, and responsible for the cleaning of the product (especially products that have been exposed to toxic chemical substances or harmful substances to the human body)

④ When returning the product to the factory, please pay attention to the packaging specifications to prevent damage to the pump during transportation; Labbox will not be responsible for product damage caused by improper packaging and will not be included in the warranty.

## Warranty

This instrument is warranted to be free from defects in materials and workmanship under normal use and service, for a period of 24 months from the date of invoice. The warranty is extended only to the original purchaser. It shall not apply to any product or parts which have been damaged on account of improper installation, improper connections, misuse, accident or abnormal conditions of operation.

For claim under the warranty please contact your supplier.

### Nota importante para los aparatos electrónicos vendidos en España

Instrucciones sobre la protección del medio ambiente y la eliminación de aparatos electrónicos:



Los aparatos eléctricos y electrónicos marcados con este símbolo no pueden ser eliminados en forma de residuos urbanos.

De conformidad con la Directiva 2012/19/UE, los usuarios de la Unión Europea de aparatos eléctricos y electrónicos, tienen la posibilidad de devolver sus RAEE para su eliminación al distribuidor o fabricante del equipo después de la compra de uno nuevo. La eliminación ilegal de aparatos eléctricos y electrónicos es castigada con multa administrativa.

### Remarque importante pour les appareils électroniques vendus en France

Informations sur la protection du milieu environnemental et élimination des déchets électroniques :



Les appareils électriques et électroniques portant ce symbole ne peuvent pas être jetés dans les décharges.

En réponse à la réglementation, Labbox remplit ses obligations relatives à la fin de vie des équipements électriques de laboratoire qu'il met sur le marché en finançant la filière de recyclage de ecosystem dédiée aux DEEE Pro qui les reprend gratuitement (plus d'informations sur [www.ecosystem.eco](http://www.ecosystem.eco)).

L'élimination illégale d'appareils électriques et électroniques est punie d'amende administrative.

### Nota importante per le apparecchiature elettroniche vendute in Italia

Istruzioni sulla protezione ambientale e sullo smaltimento dei dispositivi elettronici:



Le apparecchiature elettriche ed elettroniche contrassegnate con questo simbolo non possono essere smaltite come rifiuti urbani.

In conformità con la Direttiva 2012/19 / UE, gli utenti dell'Unione Europea di apparecchiature elettriche ed elettroniche hanno la possibilità di restituire i propri RAEE per lo smaltimento al distributore o al produttore di apparecchiature dopo averne acquistato uno nuovo. La rimozione illegale di apparecchiature elettriche ed elettroniche è punibile con una sanzione amministrativa.

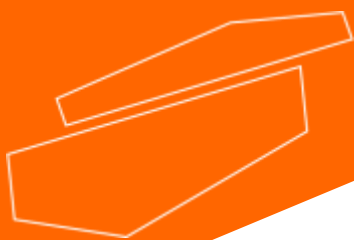

[www.labbox.com](http://www.labbox.com)